

Manometric granite table SGM - 700



Scope

Installation of piston gauges or other equipment requiring high rigidity of the structure, as well as a flat and smooth surface for operation.

Advantages

- Specially designed system for fixing the table top with damping without the use of rubber spacers to ensure the required rigidity under heavy load created by the piston gauges;
- a table top made of solid polished gabbro-diabase granite possessing high strength characteristics, resistance to abrasion and mechanical impacts;
- rigid frame with high-strength coating;
- the structure of the frame allows to use the space under the table for storing a set of weights;
- -adjustable supports, allowing the table to be installed strictly horizontally, compensating for uneven floors.

Main technical and operational characteristics

	SGM-700
Dimensions of granite table top (WxDxH), mm	700×600×60
Table top operating area	polished granite
Maximum permissible load, kg	250
Height of the table assembly (with the lower supports unscrewed by 10 mm, and the upper ones by 5 mm), mm	850
Table assembly weight, kg, max.	100
Table top weight, kg, max.	80

Overall dimensions

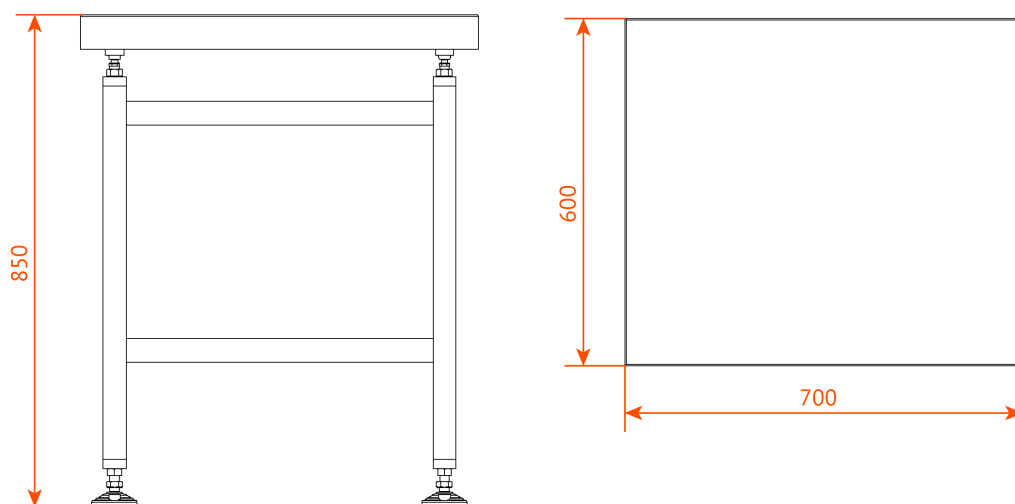

Scope of delivery

Standard delivery:

- Granite slab complete with mounting elements of the system for fastening to the frame;
- table frame;
- set of lower and upper supports.

As per additional order:

- Dimensions of the table top and the frame under special order.